



RCS Interworking Guidelines
v1.0
1 October 2009

This is a non-binding permanent reference document of the GSM Association.

Security Classification – NON-CONFIDENTIAL GSMA Material

Copyright Notice

Copyright © 2009 GSM Association

Antitrust Notice

The information contain herein is in full compliance with the GSM Association's antitrust compliance policy.

Table of Contents

1	INTRODUCTION	3
1.1	Overview	3
1.2	Roaming	3
1.3	Legacy	4
1.4	Peer-to-Peer	4
1.5	Terms.....	4
1.6	References.....	4
2	Overall IMS NNI Architecture	5
2.1	Introduction	5
2.2	Ici/Izi Interfaces	5
2.3	Mw/Gi Interfaces	6
2.4	Overview	6
3	IP Interconnection.....	7
3.1	Overview	7
3.2	IPX	7
4	XDM & Presence	9
5	SIMPLE IM	9
6	Identification.....	10
7	DNS & ENUM	11
8	Conclusion	11
9	DOCUMENT MANAGEMENT	12

1 INTRODUCTION

1.1 Overview

This document illustrates the inter-operator aspects of RCS (Rich Communication Suite). Aim is to minimize any interoperability issues when deploying RCS service between operators by making sure guidelines for deployment options are documented. This is necessary for example due to number of different possible implementation alternatives existing in the corresponding specifications. Intention is not to reinvent the wheel by creating new specifications, just reuse those already existing by making sure NNI specific details of RCS are well documented.

Relevant RCS documents:

- “Functional Description” details the service features that define RCS Release
- “Technical Realization” illustrates the technical details of different RCS services
- “Endorsement of OMA SIP/SIMPLE IM 1.0” describes which sections of the OMA SIMPLE IM specification RCS Release utilizes

For further information about RCS, see www.gsmworld.com/rcs

UNI specific issues are out of scope, since they do not directly impact NNI. So whether UNI used for accessing the home network RCS services happens to be for example 2G, 3G, GAN or ADSL is transparent from NNI point of view.

In general the following RCS services are relevant for this study:

- Presence based on OMA SIMPLE Presence & XDM
- Chat based on OMA SIMPLE IM
- File Transfer based on OMA SIMPLE IM
- Video Share based on GSMA IR.74
- Image Share based on GSMA IR.79

General GSMA interworking guidelines are fully applicable also in case of RCS, so for example guidance given in IR.34, IR.40, IR.52, IR.65, IR.67 and IR.77 related to issues such as addressing, routing, QoS and security need to be taken into account. They are not listed in detail within this document. See <http://www.gsmworld.com/newsroom/document-library/index.htm>

It should be noted that in general GSMA context “interworking” means in fact the same as “interconnection”. Thus, for example “IM interworking” here does not imply conversion between different messaging technologies but interconnection of IM between operators.

1.2 Roaming

For roaming it is assumed that the existing 2G/3G roaming will be used as it is, i.e. IP based traffic related to RCS services (e.g. SIP signaling, RTP video or MSRP messaging) is carried inside the normal GTP tunnel from the Visited Network SGSN to the Home Network GGSN. Therefore roaming as such does not pose any major impacts to RCS and thus this study can concentrate on interworking specific aspects.

Visited GGSN roaming, whilst beneficial from optimal routing/QoS point of view, is not considered to be a realistic option for wide scale deployment. At least not in the near future.

1.3 Legacy

“Legacy” components including CS voice, CS video, SMS and MMS are expected to work as they are today, so there’s no need for additional guidelines for them in RCS context per se.

Note that it is also possible to run CS based services over PS based inter-operator network, using e.g. MSC-S/SIP-I and SIGTRAN technologies. This, however, is transparent to RCS and therefore out of scope for this particular document. See corresponding IREG documentation (such as IR.83) for further details.

1.4 Peer-to-Peer

P2P services (Video Share & Image Share) that use direct terminal-to-terminal PS connection (Gi* interface between Operator A GGSN and Operator B GGSN) are not explicitly documented here since they do not need any additional support apart from the normal GGSN<=>GGSN connectivity required in interworking.

* Or 3GPP Izi interface between TrGWs, depending on the model used (see Chapter 2)

1.5 Terms

Term	Description
BG	Border Gateway
CS	Circuit Switched
IBCF	Interconnection Border Control Function
IMS	IP Multimedia Subsystem
NNI	Network-to-Network Interface
P2P	Peer-to-Peer
PS	Packet Switched
RCS	Rich Communication Suite
TrGW	Transition Gateway

1.6 References

Document	Name
23.228	3GPP IP Multimedia Subsystem (IMS);Stage 2
29.165	3GPP Inter-IMS Network to Network Interface
IR.34	GSMA Inter-Service Provider IP Backbone Guidelines
IR.65	GSMA IMS Roaming and Interworking Guidelines
IR.74	GSMA Video Share Interoperability Specification
IR.77	GSMA Inter-Operator IP Backbone Security Requirements For Service Providers and Inter-operator IP backbone Providers
IR.79	GSMA Image Share Interoperability Specification
IR.83	GSMA SIP-I Interworking Description

Document	Name
SIMPLE IM	OMA SIMPLE IM Enabler
SIMPLE Presence	OMA Presence Simple Enabler
XDM	OMA XML Document Management Enabler

2 OVERALL IMS NNI ARCHITECTURE

2.1 Introduction

This chapter illustrates the general overall architecture of IMS NNI. This forms an important part of RCS NNI since RCS heavily utilizes IMS core system as specified by 3GPP to perform a number of key duties such as handling of SIP signalling, authentication, authorization, charging and routing support.

2.2 Ici/Izi Interfaces

3GPP Release 8 introduces new border nodes and interfaces specifically for the purpose of IMS NNI. Ici interface is used to transport SIP signalling, while Izi interface handles media traffic.

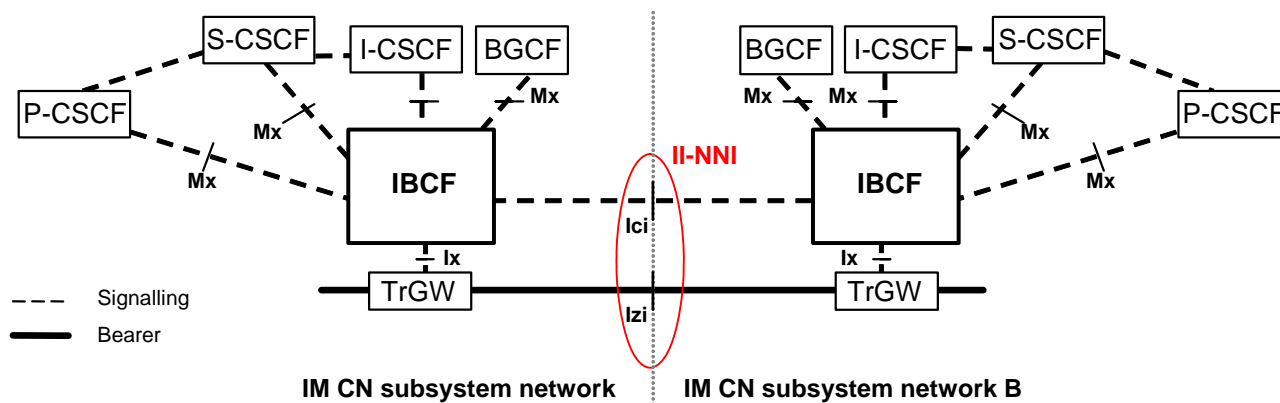

Figure 1: IMS interconnection using Ici & Izi Interfaces (from 3GPP TS 23.228)

Figure 1 shows this model where IBCF (Interconnection Border Control Function) is a node handling control plane for the purpose of e.g. THIG, ALG, screening of SIP signalling information and generation of CDRs. TrGW (Transition Gateway) is controlled by IBCF and provides functions such as NAT-PT and IPv4/6 conversion for the user plane.

Further information regarding this model can be found in 3GPP TS 29.165.

2.3 Mw/Gi Interfaces

Figure 2 presents IMS interworking between originated and terminated network as specified in 3GPP Release 5 IMS NNI. SIP controlling is delivered via Mw interface and user plane is transported via Gi interface. The actual IMS user traffic (such as Video Share stream) is routed directly between the involved GGSNs, while SIP controlling always flows via IMS core networks. I-CSCF is used as a contact point between operator networks. S-CSCF of originating network discusses either directly or via I-CSCF with I-CSCF of terminating network.

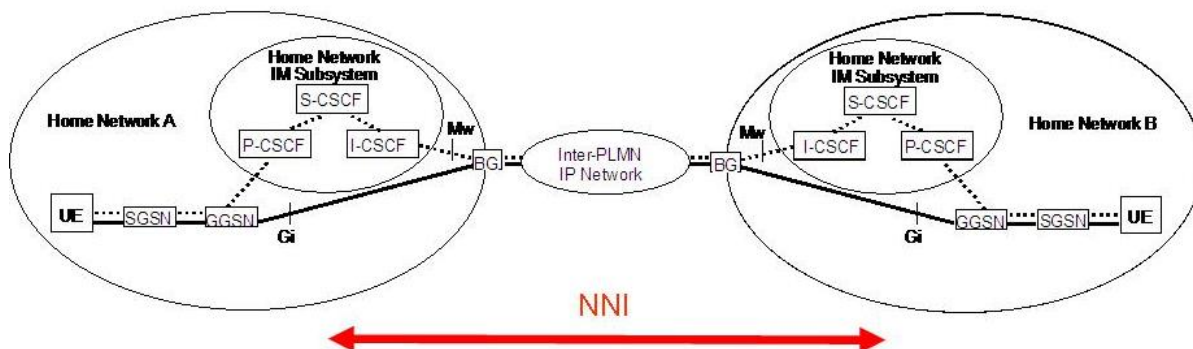

Figure 2: Mw & Gi Interfaces (simplified example missing e.g. FW nodes)

BG shown in the figure is non-SIP aware element taking care of controlling incoming traffic from IPX into the operator core system for example by performing filtering on IP layer. In addition to BG other nodes relevant for IMS NNI is for example SIP aware FW located between BG and I-CSCF. I-CSCF itself natively takes care of the being the point of access to IMS.

2.4 Overview

Whilst 29.165 illustrates NNI using IBCF & TrGW nodes, it actually only shows the interface profile between two operators. I.e. doesn't place any requirements as such on how the operator core network is implemented as long as the behaviour over Ici and Izi interfaces is as expected.

One related issue is that IBCF & TrGW do not solve all the issues related to IP based inter-operator related cases in general since they handle only SIP based traffic and associated user plane traffic. So for example traffic filtering at the border of operator core network concerning PS roaming using GTP must be taken care by some other node, somehow.

Timing should also be considered since it is expected that Rel-8 compliant IMS core systems including a complete set of border functions might not be widely available for quite some time. Additional aspect related to timing is that border nodes functioning in service/application layer need to be aware of all the protocols flowing through them, e.g. TrGW must understand MSRP in order to handle it. Experience from various tests & trials indicate that adding support for additional media protocols into border nodes might take a very long time, thus further delaying the introduction of RCS interworking.

Therefore, it should be noted that both the option of using Mw/Gi interfaces as well as the option of using Ici/Izi interfaces are possible in RCS NNI. I.e. individual operators can select the most optimal solution suitable.

3 IP INTERCONNECTION

3.1 Overview

There is a clear need for IP based inter-operator connection in RCS, simply because RCS is largely an IP based service. I.e. existing CS/TDM based networks used for transporting voice between the operators are not enough for the needs of RCS since they cannot be used for transporting e.g. SIP signalling or MSRP media.

IPX (IP eXchange) is an evolved version of GSMA GRX (GPRS Roaming eXchange) private inter-operator IP backbone which has been commercially used since year 2000 e.g. for all PS roaming traffic between GSMA operators. IPX has been selected by GSMA as the preferred mechanism for the general IP roaming and interconnection, including various services such as SIP-I based Packet Voice Interconnection (PVI). Therefore also this document concentrates on the model where IPX is utilized. This is in line with the existing IMS interworking recommendation given in IR.65 (*“consequently, preferred inter-PLMN network also in IMS case is GRX, as it is already preferred network in e.g. GPRS roaming, MMS interworking and WLAN roaming”*).

IPX is seen as the most optimal solution for providing the necessary global reach with low and predictable delay in a secure environment, that is something that is impossible to reach for example by internet based RCS NNI.

For the avoidance of a doubt, this does not exclude usage of other alternatives, such as bilateral leased line, for RCS interworking purposes when seen fit by the participating operators.

3.2 IPX

IPX is a global, private, IP network which supports end-to-end quality of service and the principle of cascading interconnect payments. IPX is completely separated from the public internet. IPX architecture consists of different IPX Providers connecting together via an IPX peering point for traffic exchange. Both signalling (such as SIP) and media (such as RTP) is transported within the IPX network. In IPX all parties are bound by the end-to-end SLA. IPX can be used to transport any IP based service between operators, both in roaming and interworking scenarios.

Figure 3 shows a high-level point of view of IPX network connecting three operators with two IPX providers.

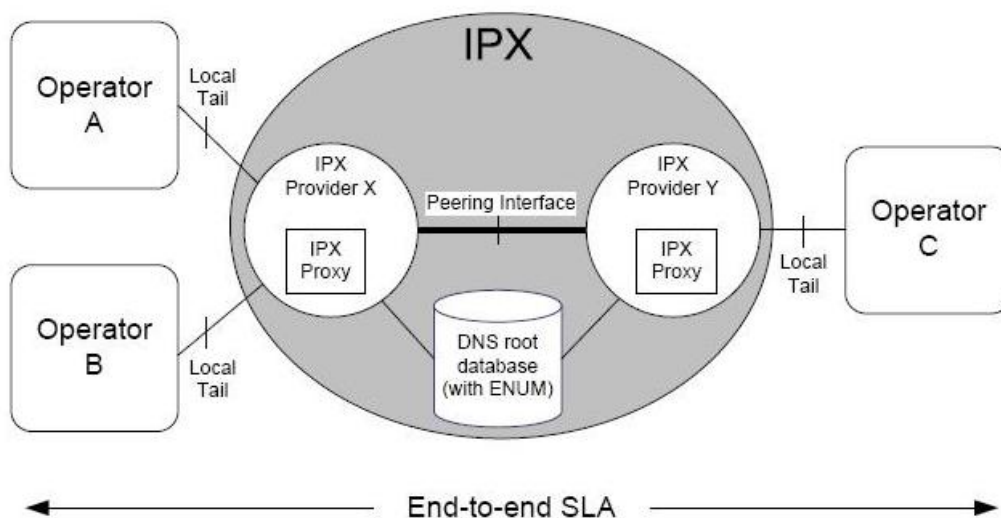

Figure 3: High-Level View of IPX (from IR.34)

IPX has three connectivity options:

- **Transport-Only Connectivity Option**
A bilateral agreement between two Service Providers using the IPX transport layer with guaranteed QoS end-to-end. This model is not service aware
- **Bilateral Service Transit Connectivity Option**
A bilateral agreement between two Service Providers using the IPX Proxy functions and the IPX transport layer with guaranteed QoS end-to-end. This model provides the opportunity to include service-based interconnect charging in addition to the transport charging of the transport-only model
- **Multilateral Service Hub Connectivity Option**
A model providing multilateral interconnect with guaranteed end-to-end QoS and including service-based interconnect charging. Hubbing/multilateral connectivity is where traffic is routed from one Service Provider to many destinations or interworking partners via a single agreement with the IPX Provider. The hub functionality is provided by IPX Proxies

It should be noted that IPX Proxy is not needed for RCS interworking as such since IPX using Transport-Only Option can handle the basic transportation of RCS traffic from one operator to another.

In practise IPX offers the support of necessary carrier-grade QoS features, security and global reach for any IP based service used between different operators, including RCS. IMS NNI as utilized by RCS as it is, i.e. it can be run over IPX without any changes needed since from IMS core system point of view IPX is just an IP network. So there's no need for modifications of either 3GPP IMS specifications or IMS node implementations due to inclusion of IPX.

For further information on IPX, please see e.g. IR.34.

4 XDM & PRESENCE

OMA XDM (XML Document Management) is an enabler which is used for storing user-specific service-related information using XML documents in the network where they can be located, accessed and manipulated by different end-user services (e.g. Presence and IM). For example XDMS (XDM Server) is utilized for storing all presence-related lists, such as the list of subscribed contacts (“buddy list”) and the presence authorization lists. XDM enabler itself is not visible to the end-user as such.

SIP based Presence enabler forms the core part of RCS, allowing end-users to see the Social Presence and Service Capability information of others, for example using the Enhanced Address Book of RCS client. This information can be then utilized for the actual session setup.

Note that the RCS Release 1 feature set is reduced compared to the full set of features offered by OMA XDM & Presence specifications. For example limited XQuery is not utilized by RCS. For further info see “RCS Technical Realization”.

- In XDM the XCAP protocol (HTTP PUT/GET/POST/DELETE) is used for XML document management, search etc
- SIP used for subscribing / notifying via IMS core system
- Presence uses SIP messages for subscribing/notifying changes to Social Presence and Service Capability states (such as “Now in Meeting” text in the Note field)
- All SIP SUBSCRIBE / NOTIFY / 200 OK etc messages routed via IMS core systems of watcher and present source
- A specific logical element called the Cross-Network Proxy is used as the single contact point for XDM enablers located in different networks. It performs the following functions
 - a. Performs authorization of the trusted network
 - b. Routes individual outgoing XCAP requests to the Cross-Network Proxy of the remote network
 - c. Routes individual incoming XCAP responses to the Aggregation Proxy
 - d. Optionally performs compression/decompression;
 - e. Support secure data transfer between Cross-Network Proxies using TLS or other means (note: when a secure network such as IPX is used, there’s no need to utilize TLS since security is offered by the network itself)
- In XDM enabler the XCAP (over HTTP) traffic between Cross-Network Proxies of different domains is used over the NN-1 reference point
- Signalling used for XDM enabler uses IP-1 reference point between IMS core systems corresponding to 3GPP Mw* interface, i.e. SIP
 - * Or 3GPP Ici interface, depending on the model used (see Chapter 2)

5 SIMPLE IM

OMA SIMPLE IM (SIP based Instant Messaging) is utilized for IP based messaging to complement the existing SMS and MMS services by offering e.g. group chat type of functionality. Also File Transfer is handled via SIMPLE IM using MSRP protocol.

Note that the RCS Release 1 feature set is reduced compared to the full set of features offered by OMA SIMPLE IM specifications. For example Pager Mode, Large Message Mode and Group Messages are not supported in RCS Release 1. For further information see “Endorsement of OMA SIP/SIMPLE IM 1.0”.

SIMPLE IM NNI consists of IM-8 between IM Servers (MSRP) and IP-1 between IMS core systems (SIP) (IP-1 same as used by XDM & Presence, i.e. 3GPP Mw interface). In addition IM-2 is utilized between IMS core system and IM server, but this is an intra-operator interface (standard 3GPP ISC interface between IMS and AS) and therefore out of scope for this study.

OMA SIMPLE IM specifications allow various deployment options to be taken, for example in interworking scenario both operators use IM server, only one operator uses IM server or none of the operators use IM server (i.e. IM messages are routed in P2P fashion between the clients in 1-to-1 messaging session). In addition it is possible to separate signalling and media paths so while signalling might be routed via IM server(s), media could be using P2P mode instead.

So in a nutshell there are multiple different deployment models that can be supported. However, for RCS NNI it would be better to concentrate on a single architectural option, for example due to interoperability reasons. Thus, it is recommended that operators deploying RCS NNI would utilize the model where both originating and terminating operator are always using IM server, both for signal and media paths. I.e. IM traffic uses server-to-server connection over NNI.

One of the clear advantages of utilizing IM server is that it supports the possibility of offering multiparty chat. Using IM server is also helpful for the purpose of performing charging per message (i.e. at MSRP level).

IM server deployed for the RCS purposes has capabilities of functioning both as Controlling as well as Participating IM Function. The Participating IM Function acts as an IM service point for users, offering IM access and service policies. Controlling IM Function is used for example in case of group communication for the IM server that owns or shares the group identity.

6 IDENTIFICATION

Identification of services is an important aspect of interworking. For example possible intermediate IPX nodes (such as IPX Proxy), and also terminating networks as regards securing inter-operator service agreements and potential termination fees etc. While charging and agreement aspects are out of scope for this document (and for IREG in general), there’s still the need to provide technically this functionality which then could be utilized commercially.

- Presence: SIP (SUBSCRIBE/NOTIFY with event = "presence") + XCAP (GET for service "presence content XDMS")
- Chat: SIP (INVITE with feature tag "oma.sip-im" without SDP a=file-selector) + MSRP
- File Transfer: SIP (INVITE with OMA IM feature tag + SDP a=file-selector) + MSRP
- Video Share: SIP (INVITE with VS feature tag)

- Image Share: SIP (INVITE with IS feature tag)
- Voice: legacy CS speech
- Video telephony: legacy CS 3G-324M
- Store & forward message: legacy SMS/MMS

7 DNS & ENUM

For DNS usage in RCS interworking, see general IMS related guidelines in IR.67 Chapter 4.5. ENUM guidelines as illustrated in IR.67 Chapter 5 are applicable also for the purpose of RCS, including MNP issues are described in Chapter 5.7.

8 CONCLUSION

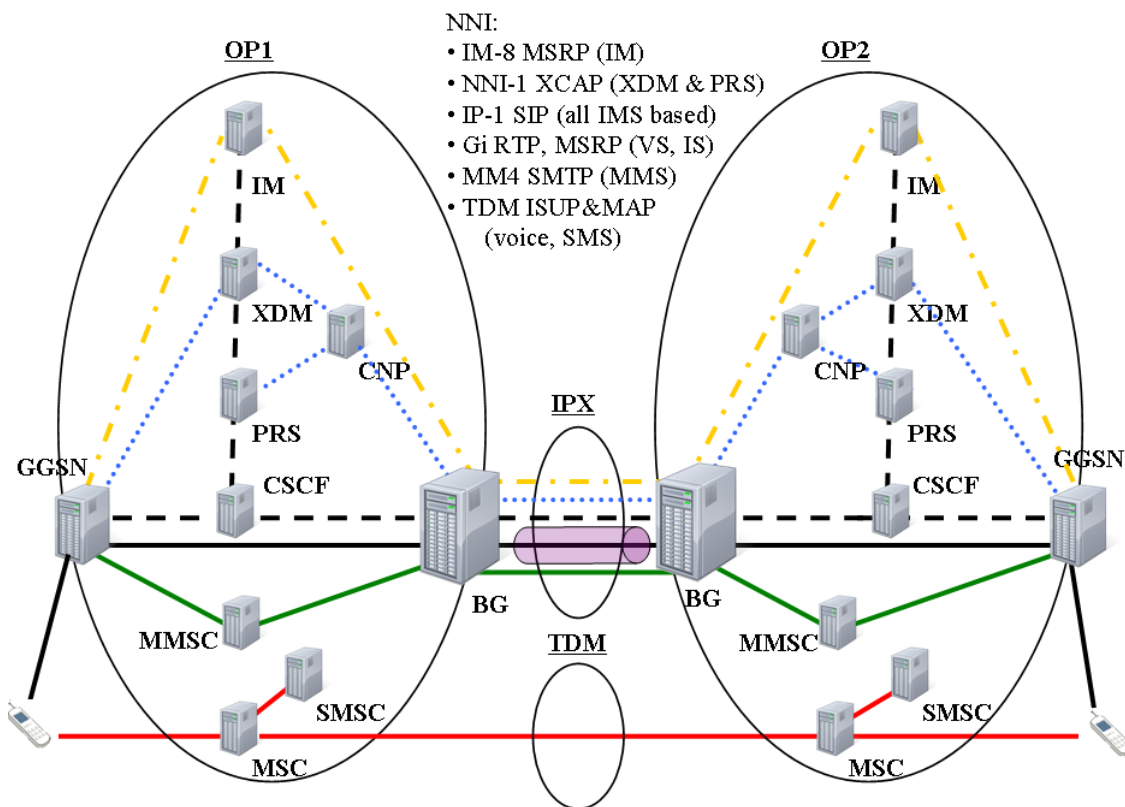

Figure 4: RCS NNI in a Nutshell

RCS NNI consists of interfaces

- IP-1: SIP between IMS core systems, 3GPP Mw* interface (*all services*)
- NNI-1: XCAP over HTTP between cross-network proxies (*XDM & SIMPLE Presence*)
- IM-8: MSRP between IM Servers (*SIMPLE IM*)

- In addition to following interfaces which are not affected by RCS as such
- Gi^{**}: RTP/RTCP, MSRP between terminals (*Video Share, Image Share*)
 - MM4: SMTP between MMSCs (*MMS*)
 - TDM/ISUP (*CS voice/video*), can be used also over IP with SIP-I
 - TDM/MAP (*SMS*), can be used also over IP with SIGTRAN

* Or 3GPP Ici interface, depending on the model used (see Chapter 2)
 ** Or 3GPP Izi interface, depending on the model used (see Chapter 2)

Underlined in the text above are the protocols the inter-operator network as well as operator core network components (such as SBC) at least needs to support when deploying RCS interworking between operators.

9 DOCUMENT MANAGEMENT

Document History

Version	Date	Brief Description of Change	Approval Authority	Editor / Company
0.1	12/02/09	Very first early draft		
0.2	20/02/09	Minor update		
0.3	17/03/09	Major update		
0.4	31/03/09	Version for Kista workshop		
0.5	15/04/09	Update based on Kista workshop feedback		
0.6	04/06/09	Major update for RCS Berg meeting		
0.7	19/06/09	Update based on RCS#5 discussions		
0.8	01/07/09	Update based on PWP#40 discussions		
0.9	20/07/09	Updated based on email approval comments		
0.91	19/08/09	Final version for DAG		
1.0	01/10/09	Final approved version for public distribution		

Other Information

Type	Description
Document Owner	IREG
Editor / Company	Tero Jalkanen / TeliaSonera